



**OMNIFinger™ Articulating Click'aV® Ligating Clip Applier**  
Instructions for use

Ref. no. **With HERO™ mechanism (High Energy Override):**  
0301-04MEOMN, 0301-04MEOMNB, 0301-04MEOMNX, 0301-04MEOMNBX, 0301-04MLEOMN, 0301-04MLEOMNB, 0301-04MLEOMNX, 0301-04MLEOMNBX;  
**Without HERO™ mechanism:**  
0301-04LEOMN, 0301-04LEOMNB, 0301-04LEOMNX, 0301-04LEOMNBX, 0301-04XLEOMN, 0301-04XLEOMNB, 0301-04XLEOMNX, 0301-04XLEOMNBX.

 <p><b>Grena Ltd</b>, 1000 Great West Road, Brentford, Middlesex TW8 9HH, United Kingdom</p>	<p><b>Contact information:</b> Phone/Fax: + 44 115 9704 800</p>	<table border="1" style="margin-left: auto; margin-right: auto;"> <tr> <td style="padding: 2px;">EC</td> <td style="padding: 2px;">REP</td> </tr> </table> <p><b>MDML INTL LTD.</b> 10 McCurtain Hill Clonakilty, Co. Cork, P85 K230, Republic of Ireland</p>	EC	REP		<p align="center"><b>ENG</b> IFU-OMN-ENG-11</p>
EC	REP					



**Important:**

This instruction for use cannot be used as a manual for surgical techniques used during the work with Ligating Clip Applier. To learn adequate knowledge about surgical technique it is necessary to contact our company or authorized distributor and to acquaint with appropriate technical instructions, professional medical literature and graduate proper training under supervision of surgeon experienced in techniques of microinvasive surgery. Before use we recommend reading precisely all information included in this manual. Not being obedient to this information may lead to serious surgical consequences such as patient injury, contamination, infection, cross-infection, inability of ligation or death.

**Indications:**

Grena OMNIFinger™ Articulating Click'aV® Ligating Clip Applier is indicated for use as delivery device for Grena Click'aV® and Click'aV® Plus polymer ligating clips during laparoscopic and thoracoscopic procedures. Conformity of the size of the occluded tissue and the clips is required.  
Patient target group - adult and young patients, males and females.  
Intended users: product is intended to be used exclusively by qualified medical staff.

**Contraindications:**

DO NOT use for tubal ligation as contraceptive method due to lack of sufficient data on efficacy and safety in these conditions.  
DO NOT use for renal artery ligation during laparoscopic live donor nephrectomy.  
DO NOT use to apply clips as a tissue marker.

**Description of the device:**

OMNIFinger™ Articulating Ligating Clip Applier is a reusable surgical instrument. It is available as endoscopic surgery version only. Each size of a clip needs to be applied with corresponding and compatible clip applier. 360° rotation of the shaft and applier tip articulation facilitates clip application in difficult access areas. Appliers are non-detachable and thus are equipped with flushing channel. Flushing channel allows to wash out debris from the shaft. Lock comprising of lock trigger and lock switch is optional – if activated, blocks jaws in open position. Version without lock can be recognized by "X" index in the reference number. Bariatric versions are indicated by "B" index in the reference number.

**Only M and ML sizes of OMNIFinger™ Articulating Click'aV® Ligating Clip Appliers have integrated HERO™ (High Energy Override) mechanism which limits pressure exerted by the jaws to the factory predetermined level to prevent tissue from excessive compression. It also extends durability of the applier by decreasing load on internal mechanisms and jaws.**

**Illustration of OMNIFinger™ Articulating Click'aV® Applier (pic. I)**

- |                            |                      |                           |
|----------------------------|----------------------|---------------------------|
| 1. Handle trigger          | 4. Articulating knob | 7. Shaft                  |
| 2. Handle                  | 5. Rotating knob     | 8. Jaws                   |
| 3. Lock trigger (optional) | 6. Flushing port     | 9. Lock switch (optional) |

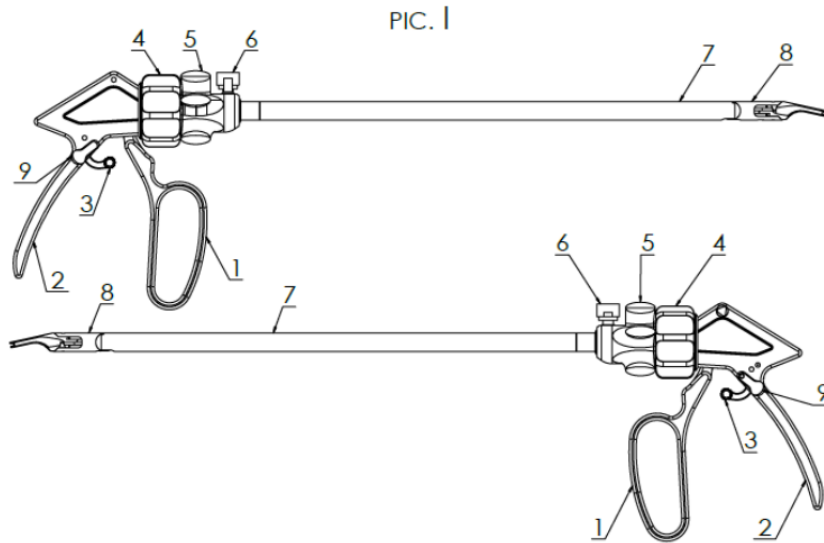

**Instructions for use:**

1. Choose the appropriate size of the clip and the compatible applier.
2. Check compatibility of all devices prior to use.
3. Following aseptic rules remove clips cartridge from the single packing. To prevent any damage to the device, place it on a sterile surface.
4. Check applier for proper action prior to use. To do it, rotate rotating knob (5) 360° in both directions (pic. II, C and D) to ensure that shaft (7) rotates without excessive resistance. Rotate articulating knob clockwise and counterclockwise to ensure applier tip articulates (pic II, A and B). Move lock switch (optional) (9) down to the position E (pic. III) what activates the lock (optional) – ensure that in such position handle trigger (1) cannot be squeezed towards handle (2) unless lock trigger (optional) (3) is kept pressed down. Lift lock switch (optional) (9) up to the position F (pic. III) to deactivate lock (optional) – ensure that in such position handle trigger (1) can be easily squeezed towards handle (2) (taking into account the note contained in point 13 which refers to M and ML sizes equipped with HERO™ system) without necessity to press down lock trigger (optional) (3) and jaws (8) close and open. Check jaws alignment. Do not use applier if any of the above tests fails.

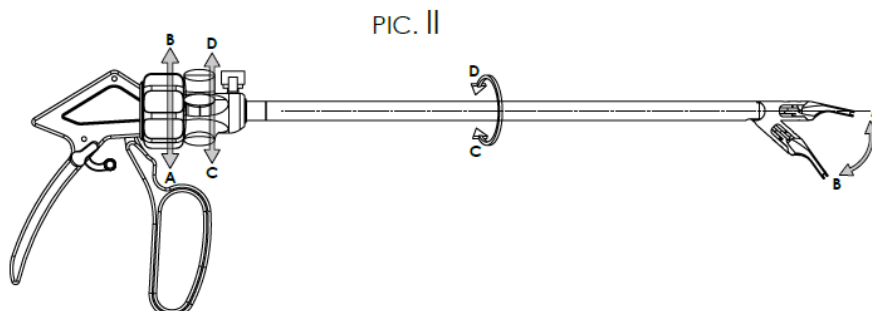

PIC. III

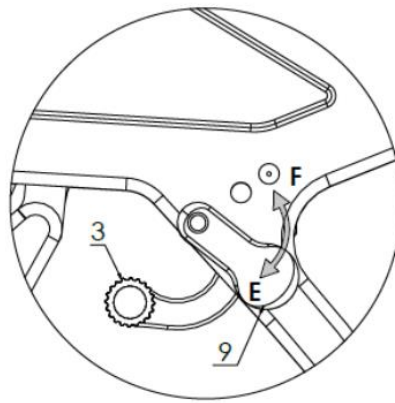

5. By rotating articulation knob (4) arrange applicator tip in straight position like on the picture I.
6. Grip the applicator around the shaft (7). Such a grip ensures that the jaws of the device remain fully open, what is essential for proper clip loading.
7. Align applicator jaws (8) vertically and laterally over a clip in the cartridge and advance product jaws into the slot of the clip cartridge making sure they are perpendicular to the surface of the cartridge. Incorrect position of the jaws during loading may lead to incorrect seating of the clip in the jaws, which may result in the inability to securely close the clip, its cracking, deformation or falling out of the applicator. Advance the jaws till there is an audible click. Do not use force to push the applicator. The applicator should move inside and outside of the slot easily. Using excessive force to push the applicator may break the clip.  
**Warning: Never attempt to load the clip if the tip of an applicator IS NOT in straight position. This can permanently damage the tool, NOT covered by the warranty. Loading of a clip can ONLY take place with the tip in straight position.**
8. Remove the applicator from the cartridge. It may be necessary to hold the cartridge to allow the clip to be removed. Make sure the clip is affixed in the jaws securely. The clip bosses should seat in the notches of the applicator jaws. Incorrect seating of the clip in the jaws, may result in the inability to securely close the clip, its cracking, deformation or falling out of the applicator.
9. Sufficiently skeletonize the structure to be ligated to allow locking mechanism of the clip to be clear of tissue to avoid penetration of the latch through the tissue. Penetration of the tissue by the latch affects closure security, may deform or even break the clip.
10. Squeeze the applicator handles (1 and 2) (but take care not to lock the clip shut) and insert the applicator jaws (8) and shaft (7) down the cannula. If lock switch (optional) (9) is in down position (pic III, position E) it is necessary to press lock trigger (optional) (3) down to allow handle trigger (1) to be moved towards the handle (2). Maintain compression on the applicator handles until the jaws clear the cannula. This procedure is necessary because cannula inner diameter is in most of the cases smaller than external dimension of opened applicator jaws. Squeezing of the applicator handles may be also necessary during applicator withdrawal from the cannula. If the handles are not sufficiently squeezed, the jaws of the applicator can scrape the material from the inside of the cannula and detached plastic particles can fall into the body cavities.
11. During application, rotate applicator shaft (7) by rotating knob (5) this way that the single tooth of the clip will go down and can be seen from the top and side at a time. This allows the user to visually confirm encapsulation of the structure being ligated and the latch of the clip being free of the tissue.
12. If necessary, use articulating knob (4) to adjust applicator tip to desired angle for easy access to the ligated structure.
13. Position the clip around the structure intended for ligation in a manner that provides clear visualization of the locking mechanism of the clip. If lock (optional) is activated\* press down lock trigger (optional) (3) or deactivate the lock (optional) by lifting lock switch (optional) (9) up. Use appropriate force to close the clip completely until it locks shut, making sure it is placed properly. Releasing the pressure on the handles (1 and 2) will cause the applicator jaws to spring open.  
**Note: When during squeezing the trigger of M and ML sizes equipped with HERO™ system perceptible resistance occurs means the HERO™ mechanism is activated. Squeeze the trigger further to override resistance and exert higher force on the jaws. HERO™ mechanism will NOT allow to exceed maximum safe force exerted on the tissue and applicator's construction.**
14. By rotating articulation knob (4) arrange applicator tip in straight position like on the picture I. Applicator remaining in articulated position cannot be removed from the trocar.
15. Remove the applicator from the surgical site with jaws in closed position.

**Compatibility:**

Click'aV® and Click'aV Plus™ clip size	Compatible OMNIFinger™ Articulating Click'aV® Ligating Clip Applicator with HERO™ mechanism	Ligated structure size in [mm]
M	0301-04MEOMN, 0301-04MEOMNB, 0301-04MEOMNX, 0301-04MEOMNBX	2 to 7
ML	0301-04MLEOMN, 0301-04MLEOMNB, 0301-04MLEOMNX, 0301-04MLEOMNBX	3 to 10
Click'aV® and Click'aV Plus™ clip size	Compatible OMNIFinger™ Articulating Click'aV® Ligating Clip Applicator without HERO™ mechanism	Ligated structure size in [mm]
L	0301-04LEOMN, 0301-04LEOMNB, 0301-04LEOMNX, 0301-04LEOMNBX	5 to 13
XL	0301-04XLEOMN, 0301-04XLEOMNB, 0301-04XLEOMNX, 0301-04XLEOMNBX	7 to 16



**Warnings and precautions measures:**

1. Carefully inspect instrument for any signs of damage after and before each use. Do not use damaged applicators. Using of damaged applicator may result in improper location of a clip. When closed, jaw tips should be directly aligned and not offset. Always check the alignment of the applicator jaws before use. If this is not done, patient injury may occur as the clip may be severely deformed during closure, preventing it from latching properly.
2. Any surgical and minimally invasive procedures should be performed only by persons having adequate training and familiarity with those techniques. Consult medical literature relative to techniques, complications, and hazards prior to performance of any surgical procedure.
3. Surgical instruments may vary from manufacturer to manufacturer. When surgical instruments and accessories from different manufacturers are employed together in a procedure, verify compatibility prior to initiation of the procedure. Failure to do this can result in inability to perform surgery.
4. Click'aV® applicators are compatible with Click'aV® and Click'aV Plus™ clips only and are not compatible with LigaV® or Vclip® clips. Always ensure that the correct Grena's applicator type was chosen prior to initiation of the procedure. Failure to do this can result in inability to perform surgery.
5. Surgeon is fully responsible to choose proper size of the clip and corresponding applicator and must determine how many clips are necessary to achieve satisfactory haemostasis and closure security
6. **Never attempt to change the angle of the tip of the device by directly applying force to the tip and ensure that bending or straightening forces are not exerted on the tip during storage, transportation, or reprocessing. This will permanently damage the applicator, not covered by the warranty. Rotating of articulating knob is the only acceptable and safe way of changing the angle of the tip.**
7. Do not use the clip loaded into the jaws or applicator alone as a dissecting instrument, as clip may drop off and applicator's tips may cause tissue injury.
8. Always confirm that the clip remains in the applicator after insertion of the applicator and clip through a cannula.
9. Do not attempt to close the jaws on any tissue structure without a clip properly loaded into the jaws. Closure of empty jaws on a vessel or anatomic structure may result in patient injury.
10. Do not squeeze the applicator over other surgical instruments staples, clips, gallstones or other hard structures as it may cause the clip to break.
11. After each clip is placed it is required to close the applicator fully. A not full squeeze may result in dislocation of the clip and therefore improper ligation.
12. Make sure every clip was placed and closed well on ligated structure. This should be repeated after the use of other surgical devices in the immediate area of the application so as not to miss accidental displacement of the clip.
13. The clip must be latched to ensure proper ligation of the vessel or tissue. Inspect the ligation site after application to ensure proper closure of the clip. This should be repeated after the use of other surgical devices in the immediate area of the application.
14. Click'aV® and Click'aV Plus™ ligating clips can be opened with specially designed clip remover. It is highly recommended that remover be readily available during surgery involving the use of Click'aV® and Click'aV Plus™ ligating clips. Open clip must be discarded and should not be reapplied again, even if there is no visible damage. Clip opened with the remover may develop microcracks and such clip could break or slip off the vessel leading to haemorrhage.
15. When working with the Click'aV® applicator, carefully follow the instructions for use of Click'aV® and Click'aV Plus™ ligating clips.
16. If it is necessary to dispose of the product, it must be done in accordance with all applicable local regulations including, without limitation, those pertaining to human health and safety and the environment.

**Ligating Clips Applicators warranty**

All Grena's Click'aV® Ligating Clips Applicators are covered by one year warranty. Grena will repair free of charge any applicator, provided it is used for normal surgical purposes with Grena ligating clips for which it was designed, and has not been repaired by unauthorized personnel. If an applicator malfunction occurs which is caused by the use of a non-Grena clips, the warranty does not apply.

**Reprocessing instructions:**

The following sections describe the preparation after use for the articles Grena's Click'aV® Ligating Clips Applicators. This includes pre-treatment at the point of use, manual cleaning and disinfection, machine processing as well as steam sterilization in the fractionated vacuum process.

<b>WARNINGS</b>	<p><b>ATTENTION:</b> Flushing channel is long and narrow. It needs special attention during cleaning to remove all the soil from it. Do not use solidifying detergents as they can clog flushing channel lumen.</p> <p><b>ATTENTION:</b> The user/processor should comply with local laws and ordinances in countries where reprocessing requirements are more stringent than those detailed in this manual. Furthermore, the hospital hygiene regulations must be observed as well as the recommendation of the relevant professional associations.</p> <p><b>ATTENTION:</b> Used devices must be thoroughly processed according to these instructions prior to use.</p> <p><b>ATTENTION:</b> <b>Universal Precautions should be observed</b> by all hospital personnel that work with contaminated or potentially contaminated medical devices. To avoid injury caution should be exercised when handling devices with sharp points or cutting edges.</p> <p><b>ATTENTION:</b> During all reprocessing steps <b>Personal Protective Equipment (PPE) should be worn</b> when handling or working with contaminated or potentially contaminated materials, devices and equipment to prevent cross-contamination. PPE includes gowns, masks, goggles or face shields, gloves and shoe covers. Observe the usual regulations for handling contaminated objects and the following precautionary measures: - Use protective gloves when touching; - Isolate the contaminated material using suitable packaging and labeling.</p> <p><b>ATTENTION:</b> <b>Do not place heavy instruments on top of delicate devices. Metal brushes or scouring pads must not be used</b> during manual cleaning procedures. These materials will damage the surface and finish of the instruments. Soft bristled, nylon brushes and pipe cleaners should be used.</p> <p><b>ATTENTION:</b> <b>Do not allow contaminated devices to dry prior to reprocessing.</b> All subsequent cleaning and sterilization steps are facilitated by not allowing blood, body fluid, bone and tissue debris, saline, or disinfectants to dry on used devices. Used devices <b>must be</b> transported to the central supply in dosed or covered containers to prevent unnecessary contamination risk.</p> <p><b>ATTENTION:</b> After the treatment is over, all parts that come into contact with the patient must be cleaned and disinfected.</p> <p><b>ATTENTION:</b> Only use cleaning agents / disinfectants approved for the reprocessing of medical devices. Observe the manufacturer's instructions for the cleaning / disinfecting agents. If unsuitable cleaning or disinfecting solutions are used, or if unsuitable cleaning or disinfection procedures are applied, this can have negative consequences for the devices: - Damage or corrosion; - Discoloration of the product; - Corrosion of metal parts; - Reduced service life; - Expiration of the guarantee.</p> <p><b>ATTENTION:</b> Grena Ltd. recommends using only EN ISO 15883-1 and -2 compliant washer-disinfectors for automated cleaning / disinfection. It is recommended that mechanical reprocessing should, if possible, be given preference over manual reprocessing methods.</p>
<b>Limitations on reprocessing</b>	<p>Instruments are delivered non-sterile and must be cleaned and sterilized before each use. <b>The first wash</b> should be performed using an ultrasonic cleaner to remove the preservative from the device. The recommended parameters are 3 min, 40 °C, 35 kHz. Extensive use or repeated reprocessing can have significant impact on the instruments. Product lifetime is determined by prints of wear and damages due to usage. Do not use damaged or corroded instruments. <b>Use of hard water should be avoided.</b> Softened tap water may be used for initial rinsing. Purified water should be used for final rinsing to eliminate limescale deposits on the devices. One or more of the following processes may be used to purify water: ultra-filter (UF), reverse-osmosis (RO), deionized (DI), or equivalent.</p>
<b>INSTRUCTIONS</b>	
<b>Point of use:</b>	<p>A pre-cleaning of the devices should be carried out immediately after treatment, taking personal protection into account. The aim is to prevent organic material and chemical residues from drying on in the lumen or on the outer parts of the instruments and to prevent contamination of the surrounding area.</p> <ol style="list-style-type: none"> <li>1. Remove excess soil, body fluids and tissue with disposable cloth/paper wipe.</li> <li>2. Submerge instrument in the water (temperature below 40°C) immediately after use.</li> <li>3. Do not use solidifying detergents or water with temperature exceeding 40°C because they can lead to sticking of the soil and influence further steps of reprocessing.</li> </ol>
<b>Containment and transportation</b>	<p>It is recommended that devices are reprocessed as soon as it is reasonably practical following use. To avoid any damage devices should be safely stored and transported to the place of further reprocessing in the closed container (e.g. tub with lid) to avoid contamination of the surrounding area. Maximum time between pre-cleaning the instrument and further steps of cleaning must not exceed 1 hour. Transport instruments to the processing room and place it in the basin with cleaning solution.</p>
<b>Preparation for cleaning</b>	<p>The device should NOT be disassembled for cleaning or sterilization. All cleaning agents should be prepared at the use-dilution and temperature recommended by the manufacturer. Softened tap water may be used to prepare cleaning agents. Use of the recommended temperatures is important for optimal performance of cleaning agents. <b>NOTE: Fresh cleaning solutions should be prepared when existing solutions become grossly contaminated (bloody and/or turbid).</b></p>
<b>Cleaning/ Disinfection: Manual</b>	<p>Equipment: pH neutral or alkaline proteolytic enzymatic detergent, soft brush, cleaning pressure pistol or high volume syringe, ultrasonic washer.</p> <ol style="list-style-type: none"> <li>1. Soak instrument in washing/disinfecting solution and follow disinfectant manufacturer instructions. (4% Secusept Plus, 15 min, 30-35 °C was used for validation).</li> <li>2. Using brush and keeping device inside the soaking solution apply washing/disinfecting solution to all surfaces ensuring that jaws are cleaned in both opened and closed positions. Make sure that all visible contamination has been removed. Flush inside of the shaft with the solution.</li> <li>3. Rinse with tap water (below 40 °C), while actuating device until there is no sign of blood or soil on the device or in the rinse stream, but for 3 minutes at least.</li> <li>4. Use cleaning pressure pistol or high volume syringe to aggressively flush inside of the shaft with tap water (below 40°C). This should be done through flushing port at proximal side of the shaft until no visible soil leaves the shaft.</li> <li>5. Dry a flushing channel with compressed medical air.</li> <li>6. Place device in ultrasonic washer filled with a washing / disinfecting solution for 3 min, 40°C, 35 kHz. The process was validated with 2% Sekusept Aktiv.</li> <li>7. Rinse under clean running water, including flushing channel (if equipped), while actuating device. UF, RO or DI water should be used for this step.</li> <li>8. Remove excess moisture from the device with a clean, absorbent and non-shedding wipe. Dry the device with compressed medical air including flushing channel.</li> </ol> <p><b>NOTE:</b> One should remember that any cleaning and disinfection process should be validated. Check visually for cleanliness to ensure that all debris have been removed. If not visually clean, repeat the reprocessing steps until the device is visually clean.</p> <p><b>NOTE:</b> It is recommended that used cleaning brushes must be cleaned after each use (if possible in an ultrasonic cleaner) and then disinfected. After cleaning and disinfection, they must be stored dry and protected from contamination.</p>
<b>Cleaning/ Disinfection: Automated</b>	<p>Equipment - Washer / disinfectant, pH neutral or alkaline proteolytic enzymatic detergent, soft brush, ultrasonic washer. Endoscopic instruments have channels, crevices and fine joints. Dried soiling is very difficult to remove from such areas by automated cleaning. In order to achieve effective cleaning, it is necessary to remove massive impurities before automated reprocessing, therefore Grena Ltd. recommends manual pre-cleaning. In particular, make sure to pre-clean the shaft before cleaning in the washer /disinfectant.</p> <p><b>Validated precleaning procedure:</b></p> <ol style="list-style-type: none"> <li>1. Remove excess soil using soft brush.</li> <li>2. Immerse instrument in a washing/disinfecting solution 15 min, 30°C - 35°C (4% Secusept Plus was used for validation). Take care to fill flushing channel with the solution.</li> <li>3. Place device in ultrasonic cleaner filled with a washing/disinfecting solution 3 min, 40°C, 35 kHz (4% Sekusept Plus was used for validation).</li> </ol> <p><b>Validated automatic cleaning procedure:</b> Grena Ltd. recommends the use of an EN ISO 15883-1 and -2 compliant cleaning / disinfection device in combination with a suitable load carrier. Follow the instructions for use of the manufacturer of the washer / disinfectant. Load instruments into the washer / disinfectant according to the manufacturer instructions. Connect flushing channels (if equipped) of the instruments to the washer / disinfectant so that it is rinsed through. The following process parameters are suitable for reprocessing the instruments:</p> <ol style="list-style-type: none"> <li>1. Cold pre-wash, water &lt;40 °C, 1 min.</li> <li>2. Washing, hot water, 10 minutes, detergent concentration and temperature as per manufacturer's recommendation (process validated with 0,7% Thermosept® RKF, 55 °C).</li> <li>3. Neutralization, neutralizing agent concentration and time as per manufacturer's recommendation (process validated with 0,15% Thermosept® NKZ, 40°C, 2 min).</li> <li>4. Rinse, cold water below 40 °C, 2 min.</li> <li>5. Thermal disinfection 90°C, 8 min, concentration of additive as per manufacturer's recommendation (process validated without any additive).</li> <li>6. Drying 110°C, 6 min.</li> </ol> <p><b>NOTE:</b> One should remember that any cleaning and disinfection process should be validated. <b>NOTE:</b> The validated parameters correspond to a process with an A0 value of &gt; 3000s. Grena Ltd. Recommends to use only processes with an A0 value of &gt; 3000s. <b>NOTE:</b> Never leave instruments wet after reprocessing. This can lead to corrosion and microbial growth. If the devices are not completely dry after machine processing has been completed, dry the appliers manually (see drying section) and stored as directed.</p>
<b>Drying:</b>	<p>Dry any remaining moisture with a clean, absorbent, non-shedding cloth. Use compressed medical air or a high volume syringe to blow flushing channel and jaws hinge until no more moisture escapes.</p>
<b>Maintenance:</b>	<p>Hinges and other moving parts should be lubricated with a water soluble product intended for surgical instruments that must be sterilized. Manufacturer's expiration dates should be adhered to for both stock and use-dilution concentrations of the cleaning / disinfecting agents.</p>

<b>Inspection and function testing:</b>	Inspect the device for functionality – in case of any technical impairment instrument must be rejected. Check the action of moving parts (e.g. jaws, hinges, connectors, knobs etc.) to ensure smooth operation throughout the intended range of motion. Check jaws for excessive play. Visually inspect for damage and wear. Pay attention to proper jaws alignment. Check the shaft for distortion. Carefully inspect each device to ensure that all visible contamination has been removed. If contamination is noted, repeat the cleaning / disinfection process. Discard damaged instruments.										
<b>Packaging:</b>	<u>Singly</u> : A standard commercially available, medical grade steam sterilization pouches or wrap may be used. Ensure that the pack is large enough to contain the applier without stressing the seals. Do not use packaging that is too large, to prevent the instruments from sliding around in the packaging. <u>In sets</u> : Appliers may be loaded into general-purpose sterilization trays. Trays and cases with lids may be wrapped in standard medical grade, steam sterilization wrap. Ensure that jaws are protected. The total weight of a wrapped instrument tray or case should not exceed 11.4 kg/25 lbs for the safety of the personnel handling instrument sets; instrument cases exceeding 11.4 kg/25 lbs should be split into separate trays for sterilization. All devices must be arranged to ensure steam penetration to all instrument surfaces. Instruments should not be stacked or placed in close contact. The user must ensure that the instrument case is not tipped or the contents shifted once the devices are arranged in the case. Silicone mats may be used to keep devices in place. Devices for validation of sterilization process were packed in pouches compliant with EN ISO 11607-1.										
<b>Sterilization:</b>	Equipment: Grena Ltd. recommends the use of a sterilizer in accordance with EN ISO 17665 or EN 285. The sterilization must be carried out in packaging suitable for the sterilization process. The packaging should comply with EN ISO 11607 (e.g. paper / laminate film). Moist heat/steam sterilization is the preferred and recommended method for Grena devices. The hospital is responsible for in-house procedures for the inspection, and packaging of the instruments after they are thoroughly cleaned in a manner that will ensure steam penetration and adequate drying. Provisions for protection of any sharp or potentially dangerous areas of the instruments should also be recommended by the hospital. Sterilizer Manufacturer's Instructions for operations and load configuration should be followed explicitly. When sterilizing multiple instrument sets in one sterilization cycle, ensure that the manufacturer's maximum load is not exceeded. Instrument sets should be properly prepared and packaged in trays and/or cases that will allow steam to penetrate and make direct contact with all surfaces. <b>CAUTION:</b> Plasma gas sterilization should not be used. <b>ATTENTION:</b> Never sterilize uncleaned instruments! The success of a sterilization depends on the previous cleaning status! Minimum validated steam sterilization parameters required to achieve a 10 <sup>-6</sup> sterility assurance level (SAL) are as follows: <table border="1"> <thead> <tr> <th>Cycle type</th> <th>Temperature [°C]</th> <th>Exposure time [min]</th> <th>Pressure [bar]</th> <th>Drying time [min]</th> </tr> </thead> <tbody> <tr> <td>Fractional prevacuum 10 kPa</td> <td>134</td> <td>3</td> <td>&gt;3</td> <td>15</td> </tr> </tbody> </table> <b>NOTE:</b> One should remember that any sterilization process should be validated prior to use. The validation of the suitability of the above parameters for the fractional vacuum process was carried out by Grena in accordance with the requirements of EN ISO 17665-1. The user is responsible for validating the correct functioning of the sterilizer.	Cycle type	Temperature [°C]	Exposure time [min]	Pressure [bar]	Drying time [min]	Fractional prevacuum 10 kPa	134	3	>3	15
Cycle type	Temperature [°C]	Exposure time [min]	Pressure [bar]	Drying time [min]							
Fractional prevacuum 10 kPa	134	3	>3	15							
<b>Storage:</b>	Sterile, packaged instruments should be stored in a designated, limited access area that is well ventilated and provides protection from dust, insects, vermin, and temperature/humidity extremes.										
<b>Additional information:</b>	The instructions provided above have been recommended by the medical device manufacturer as being CAPABLE of preparing a medical device for re-use. It remains the responsibility of the processor to ensure that the processing as actually performed using equipment, materials and personnel in the processing facility achieve the desired result. This requires validation and routine monitoring of the process. Likewise any deviation by the processor from the recommendations provided should be properly evaluated for effectiveness and potential adverse consequences. Users must then establish an appropriate cleaning protocol for the reusable medical devices used at their sites, using the recommendations of the device manufacturer and cleaner manufacturer. Because of the many variables involved in sterilization / decontamination, each Medical Facility should calibrate and verify the sterilization / decontamination process (e.g., temperatures, times) used with their equipment. It is the responsibility of the Medical Facility to ensure that reprocessing is performed using the appropriate equipment and materials, and that personnel in the reprocessing facility have been adequately trained in order to achieve the desired result.										
<b>A notice to the user and/or patient:</b>	If any serious incident has occurred in relation to the device it should be reported to the manufacturer and the competent authority of the Member State in which the user and/or patient is established.										
<b>Manufacturer contact:</b>	See the headline of instructions for use.										



Caution



Keep dry



Consult electronic instructions for use



Manufacturer



Authorized representative in the European Community



Catalogue number



Batch code



Quantity in package



Medical Device

*The hard copies of instructions for use delivered with Grena products are always in English language.  
If you require a hard copy of IFU in other language, you can contact Grena Ltd.  
at [ifu@grena.co.uk](mailto:ifu@grena.co.uk) or + 44 115 9704 800.*

*Please scan the below QR code with the appropriate application.  
It will connect you with Grena Ltd. website where you can choose eIFU in your preferable language.*

*You can enter the website directly by typing in [www.grena.co.uk/IFU](http://www.grena.co.uk/IFU) in your browser.*

*Make sure that paper version of IFU in your possession is in the latest revision prior to use of the device.  
Always use the IFU in the latest revision.*

